

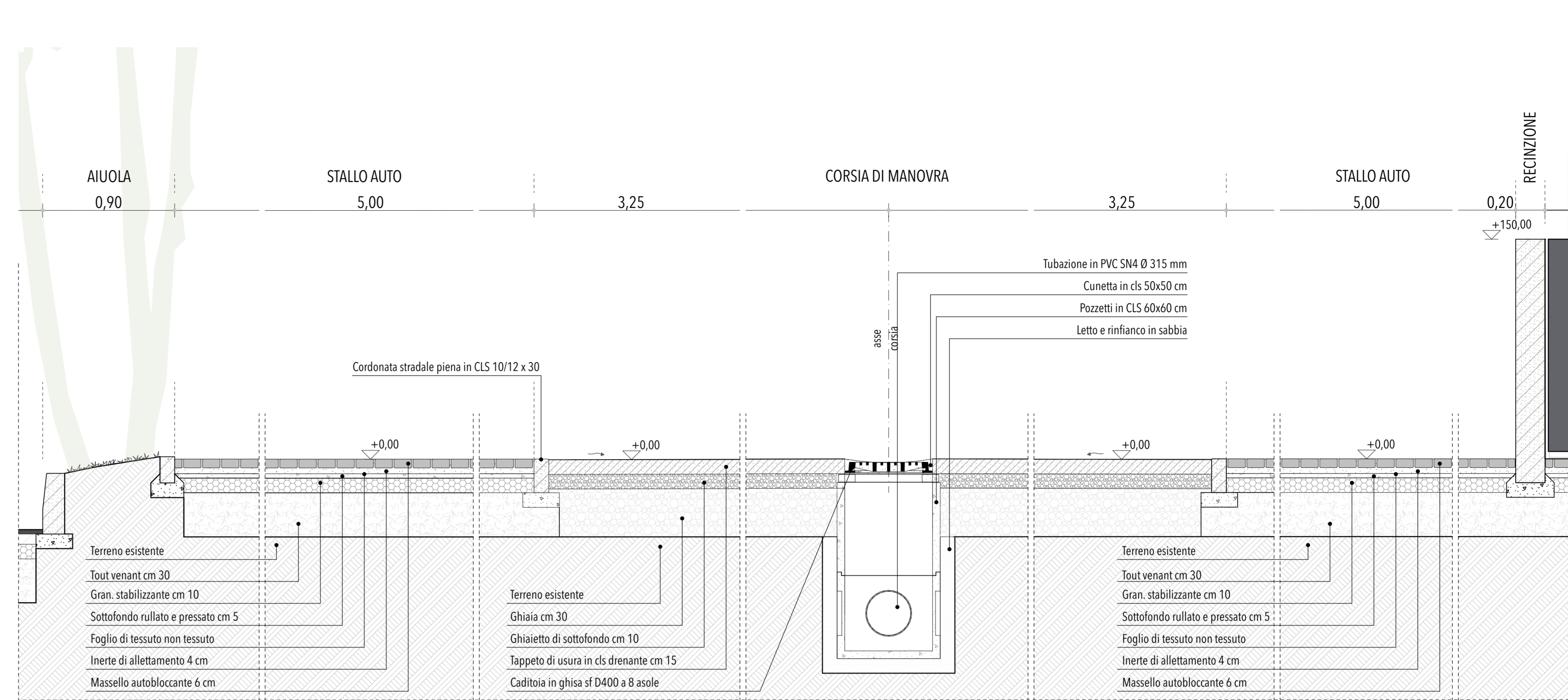

OPERE DI URBANIZZAZIONE_1:200

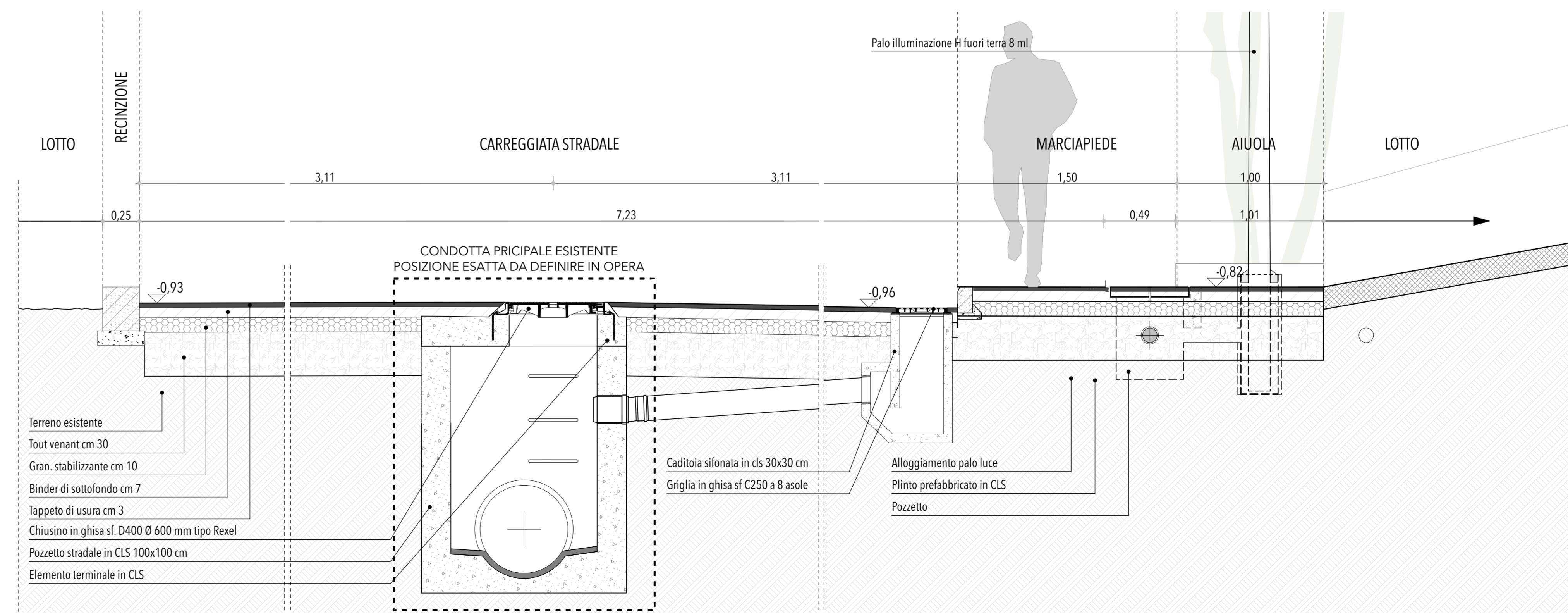

SEZIONE AA - PARCHEGGIO PUBBLICO_1:20



SEZIONE BB - SEZIONE STRADALE TIPO_1:20

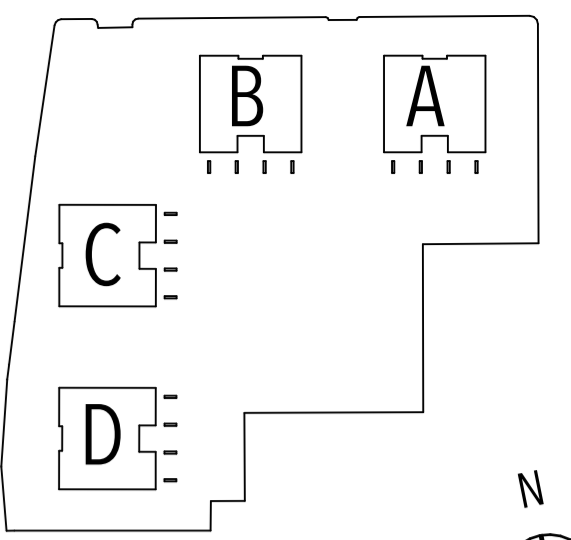

KEY PLAN UNITA'

COMUNE DI PADOVA



VARIANTE AL PUA DIEMME CON PRECISE DISPOSIZIONI PLANOVOLUMETRICHE

PROGETTO



L&Z ARCHITECTS
via Noventana 192,
35027 Noventa Padovana (PD)
T. +39 049725181 F. +39 049725181
studio@lez-a.it - www.lezarchitects.it
responsabile

Arch. Stefano Liccardo

COMMITTENTE

DUBBINI SRL
via Battaglia 69
35020 Albignasego (PD)
PIVA 02296380286

PROGETTO

DM PARK RESIDENCE

via Capra 31

NCT FG 84, mapp 208

CODICE ELABORATO

TAV.16

TAVOLA

PUA VARIANTE - OPERE DI URB.

PRIMARIA E SECONDARIA

DATA

13/07/21

NOME FILE

Nelume:PROGETTI\1912 0 U B complesso_residenziale_Padova\01_PROGETTO\012 DEFINITIVO\012-4-PROGETTO\DM Park_Progetto_PUA_var210615.pln